

WALL-PRESSURE SPECTRUM MODEL BASED ON ARTIFICIAL NEURAL NETWORKS PREDICTIONS

Andrea Arroyo Ramo^{*1,2}, Michaël Bauerheim^{†2}, and Stéphane Moreau^{‡1}

¹Faculté de Génie, Université de Sherbrooke, Sherbrooke, Canada

²Département Aérodynamique, Énergetique et Propulsion, ISAE-Supaero, Toulouse, France

1 Introduction

The wall-pressure fluctuations induced by a turbulent boundary layer (TBL) are of interest in multiple applications, among them the aeronautical sector, wind energy generation, ground transportation and general use machines with rotating components. Under clean, laminar flow, the minimum noise level produced by rotating machines comes from the interaction between the turbulent boundary layer developing on the wall and the airfoil trailing edge. Moreover, these wall-pressure fluctuations may induce fluid-structural coupling and vibro-acoustic transmission. So, there is a special interest in finding simplified models that relate the wall-pressure fluctuations –or their spectrum (WPS)– to the main characteristics of the TBL.

Several semi-empirical models have been proposed in the past. All of them relating the WPS to boundary layer statistical parameters such as inner or outer layer scaling variables, e.g. BL thickness, external velocity or friction velocity. The empirical model of Chase-Howe was modified by Goody to account for Reynolds number effects. Then, further extensions were introduced by Kamruzzaman *et al.*, Rozenberg *et al.*, Hu or Lee to account for pressure gradient effects on the boundary layer development. The main drawback of such models is that they were generated *ad-hoc* for the specific dataset used to tune the model, or they are valid only within specific ranges of pressure gradient or flow conditions.

Deep Learning has been considered as an alternative to find complex dependencies between the TBL physical parameters [1]. The use of Artificial Neural Networks (ANN) as universal function approximator may permit to find a relationship between the BL and the WPS.

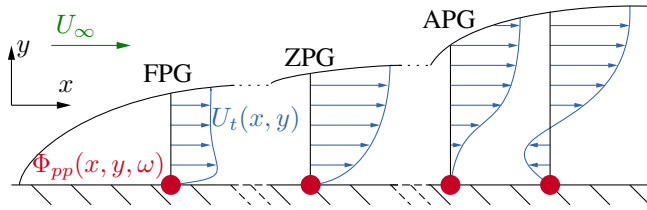

Figure 1: Boundary layer development on a flat plate. Forward, zero and adverse pressure gradient effects.

The proposed approach, differently from previous studies, uses the complete boundary layer profile. With that, the information of the flow evolution is retained in the model i.e. there is no *a-priori* choice of TBL parameters nor potential loss of relevant characteristics of the flow. The ANN training

and analysis is performed on data coming from Large Eddy Simulations (LES) of a Controlled Diffusion (CD) airfoil produced by the European SCONE project [2]. The set of data includes zero and adverse pressure gradient effects, comprising flows experiencing strong adverse pressure gradients at various Mach and Reynolds numbers, which provides a large variety of flow conditions over the airfoil surface.

2 Boundary layer and wall-pressure spectrum

The boundary layer development over a flat plate is represented in Fig. 1. The thickness of the boundary layer increases as the pressure gradient becomes more negative. To find boundary layer thickness $\delta(x)$, the recovery of the 99% of the stagnation pressure is used: $p_{tot} = p + 1/2\rho U^2$. Velocity profile in the normal direction of the airfoil suction side is collected and normalized with the free-stream velocity U_∞ .

The semi-empirical WPS models mentioned in the introduction can be collected in the Universal WPS (Eq. (1)). The constants a - h , FS and SS have different definitions for each one of the models, for instance Goody, Rozenberg and Lee [3]. These definitions rely on the use of inner and/or outer boundary layer parameters. The presence of pressure gradient effects and their strength is crucial in the formulation of such models and their range of application.

$$\phi_{pp}(\omega)SS = \frac{a(\omega FS)^b}{[i(\omega FS)^c + d]^e + [(fR_T^g)(\omega FS)]^h} \quad (1)$$

3 Numerical datasets

The dataset employed in the current study contains the numerical LES data of SCONE project [2] on the flow over a controlled diffusion (CD) airfoil. The seven LES computations are collected in Tab. 1, where the flow conditions (Mach, Reynolds and angle of attack) are specified for each one.

The data points are split in three different groups: training, validation and testing. The case C32 is reserved for testing, and the remaining cases are used for training (80%) and validation (20%). The validation dataset is used only to evaluate the training.

Table 1: Flow parameters covered by the dataset

Case	Mach [-]	Reynolds [-]	AoA [°]
C11 C12	0.3	8.30×10^5	4 7
C21	0.3	2.40×10^6	7
C31 C32 C33	0.5	2.29×10^6	4 5 6
C41	0.7	2.40×10^6	1
N pts. per case:	119	Total data:	833

*andrea.arroyo.ramo@usherbrooke.ca

†michael.bauerheim@isae-supero.fr

‡stephane.moreau@usherbrooke.ca

4 Artificial Neural Network (ANN)

A 1D ANN structure is developed for the prediction of wall-pressure fluctuations on the CD airfoil. The structure of such a network, sketched in Fig. 2, contains two main parts. First, an autoencoder (Fig. 2, bottom) is used to compress the boundary layer profile into a reduced latent space, to avoid *ad hoc* parametrization. Second, this latent space, which contains all the information to reconstruct the boundary layer, is used as an input, together with the flow and position input data, into the WPS prediction ANN (Fig. 2, top). In this architecture, three fully connected layers have been employed. Each neuron computes a weighted sum of the input components \mathbf{X} , adding a bias \mathbf{b} , and applying a nonlinear activation function σ . The output of the fully connected layer l is input into the following one: $\mathbf{y}^{(l+1)} = \sigma^{(l+1)}(\mathbf{w}^{(l)}\mathbf{y}^{(l)} + \mathbf{b}^{(l+1)})$. The training uses the NAdam optimizer (stochastic gradient descent) and the mean-squared error as loss function.

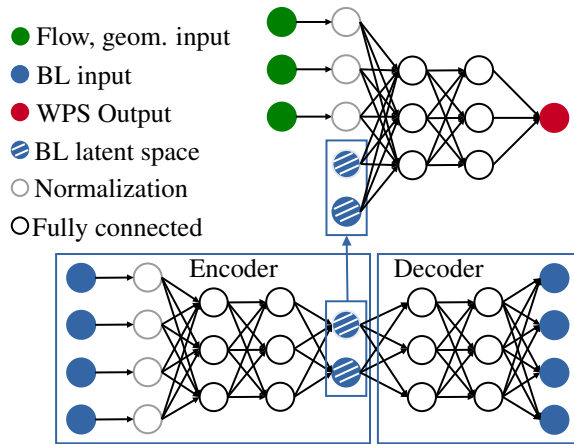

Figure 2: ANN schematic. Use of encoder as ANN input.

5 Results

The boundary layer autoencoder is used to compress the data of the velocity profile into its minimum expression. A parametric study has been performed in order to evaluate the minimal dimension of the latent space required to reconstruct the input boundary layer profile. It has been found that a three-dimensional latent space is sufficient to reconstruct accurately the velocity profile. Fig. 3 shows the reconstruction in three locations over the airfoil suction side on case C32, unseen by the autoencoder. The locations are characterized by FPG, ZPG and APG effects.

The prediction of the WPS under strong APG effects is shown in Fig. 4, as it is the regime which presents the most difficulties for the semi-empirical models. The ANN provides a good agreement with the numerical LES data available. There is an overall offset with the reference data lower than 5 dB, whereas the semi-empirical models produce, in the best case, offsets of about 10 dB. Furthermore, the trends in the low, mid and high frequency range are observed satisfactorily. It is not the case of the slopes provided by Goody, Rozenberg and Lee semi-empirical models.

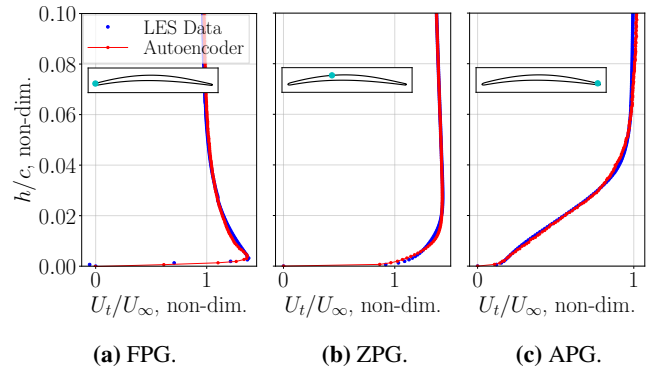

Figure 3: Boundary layer reconstruction from autoencoder on case C32, unseen during training. Encoder with 3 latent spaces.

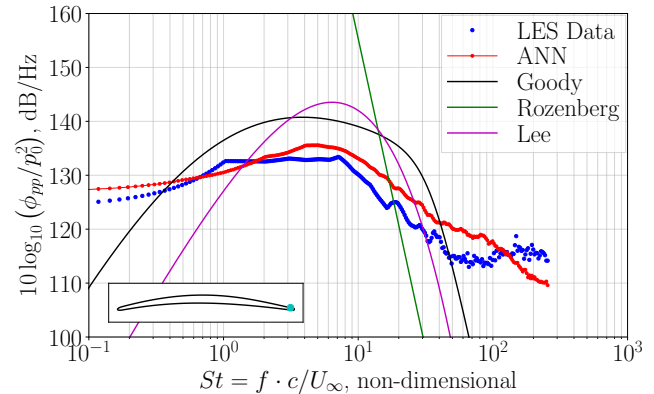

Figure 4: Prediction of the ANN, and compared to semi-empirical models. Testing on APG data of case C32, unseen during training.

6 Conclusions

The existing semi-empirical models fail to predict WPS when evaluated in cases of strong APG driving the boundary layer on a CD airfoil. ANNs have been proven to be an alternative for such predictions. It is first able to reduce the BL velocity profile into its minimum expression and then to use the latter to predict the WPS with lower error compared to semi-empirical models.

Acknowledgments

This work was partly supported by EUR-TSAE and NSERC. The Digital Research Alliance of Canada provided the computational resources.

References

- [1] Joachim Dominique, J Van Den Berghe., Christophe Schram, and M A Mendez. Artificial neural networks modeling of wall pressure spectra beneath turbulent boundary layers. *Physics of Fluids*, 34(3), 2022.
- [2] Radouan Boukharfane, Matteo Parsani, and Julien Bardart. Characterization of pressure fluctuations within a controlled-diffusion blade boundary layer using the equilibrium wall-modelled LES. *Scientific Reports*, 10(1):1–19, March 2020.
- [3] Seongkyu Lee. Empirical wall-pressure spectral modeling for zero and adverse pressure gradient flows. *AIAA Journal*, 56:1–12, 01 2018.